

Lecture 14

Relays

Relays



Mechanical relay

- Relays are electrically actuated switches
 - Mechanical relays
 - Reed relays
 - Solid-state relays

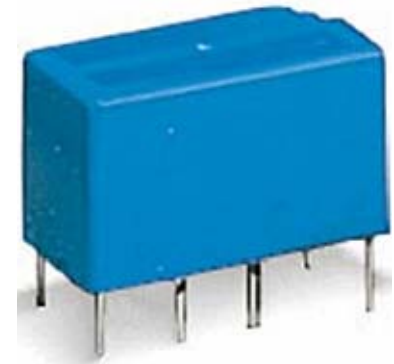

Miniature relay



Reed relay

- A relay consists of an electromagnetic coil and one or more pairs of contacts



Solid-State relay

Mechanical Relays

- Designed for high currents
 - Typically from 2A to 15A
- Relatively slow switching
 - 10ms to 100ms

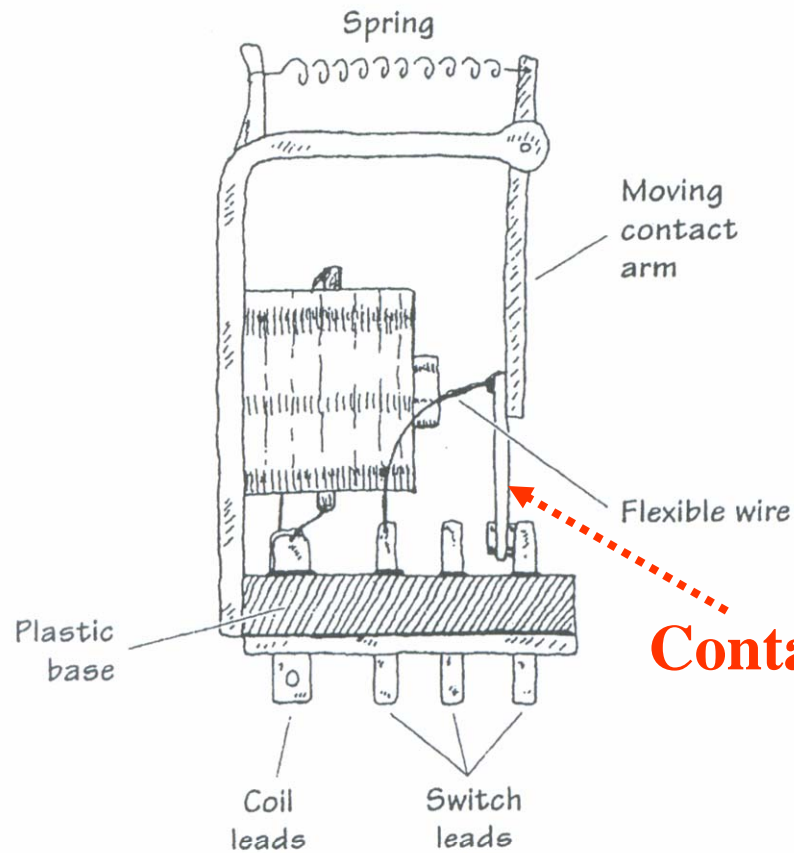

Contact switch

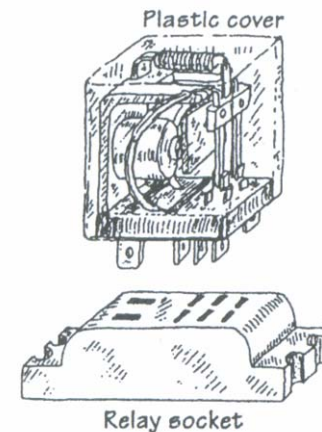

Common Symbols for Relays

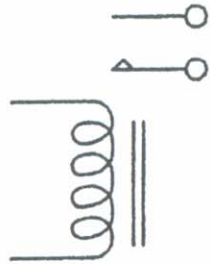

SPST (normally open)
Single Pole, Single Throw

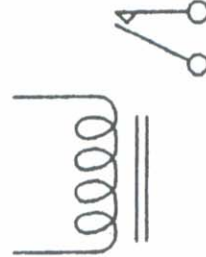

SPST (normally closed)

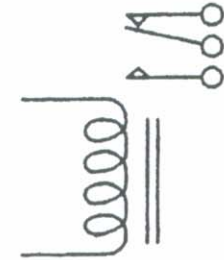

SPDT

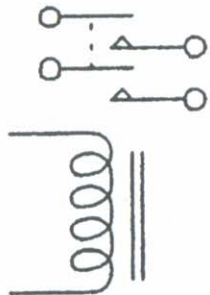

DPST (normally open)

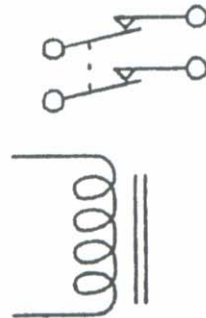

DPST (normally closed)

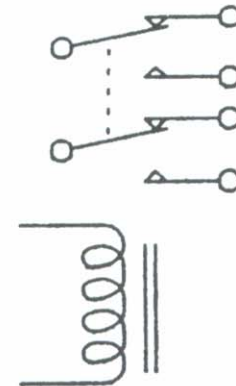

DPDT

Notes About Relays

- To make a relay change states, the voltage across of its magnetic coil should be at least within ± 25 percent of the relay's specified control voltage rating ($V_c \pm 0.25 \times V_c$)
- Sudden changes in current will create voltage spike, to avoid this is to use transient suppressors

Electromechanical Relay

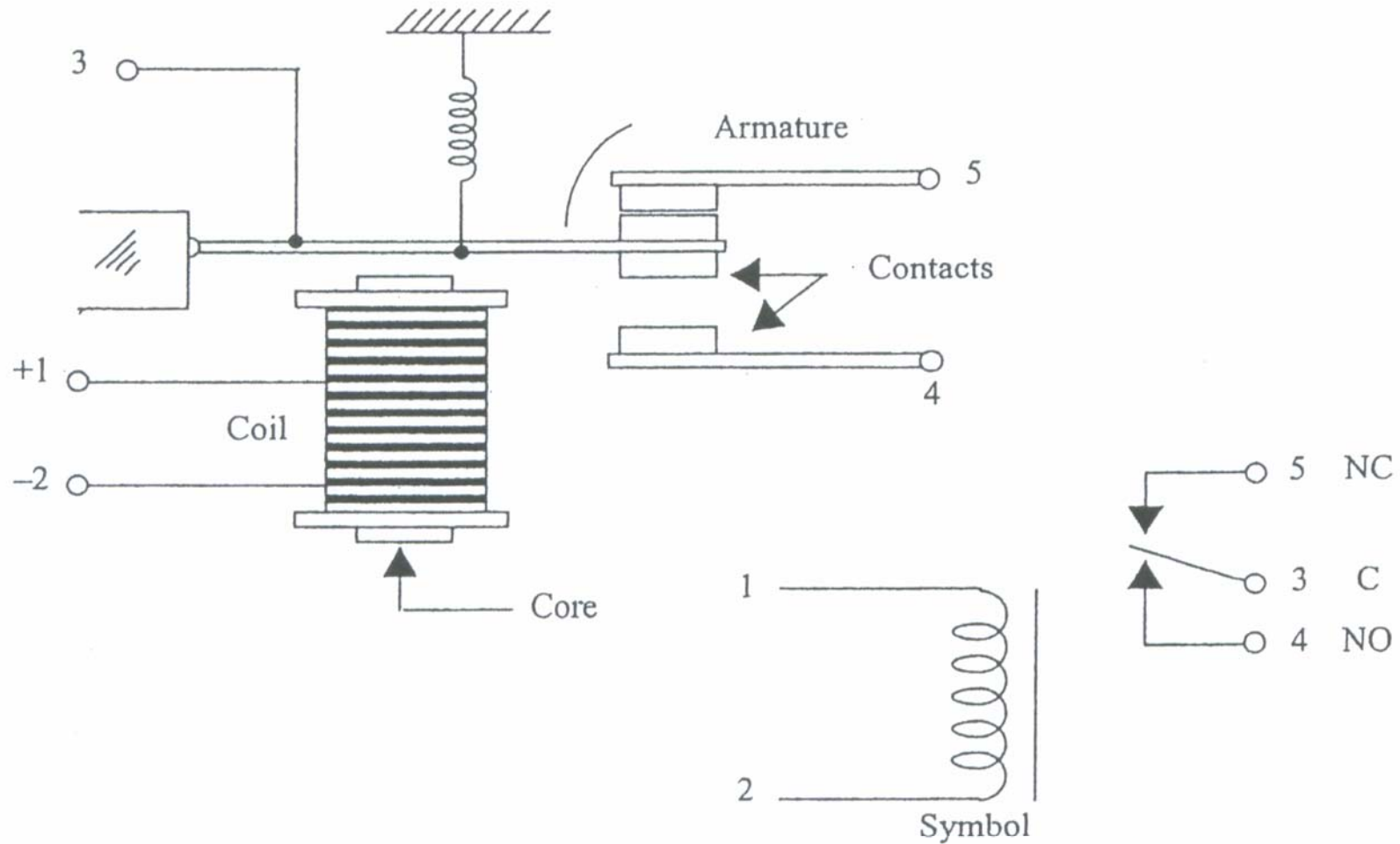

Relays with BS2

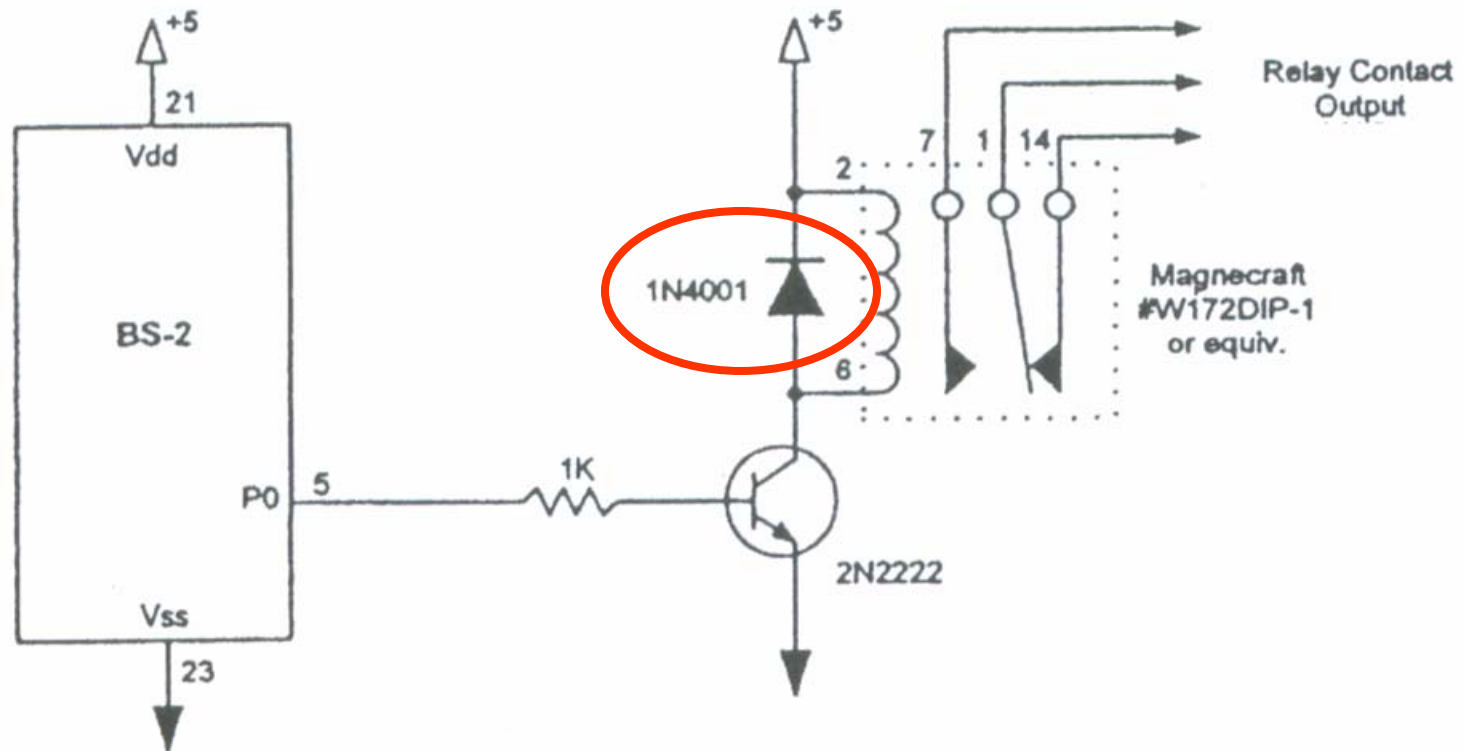

Using an NPN transistor to drive a relay

Reed Relays

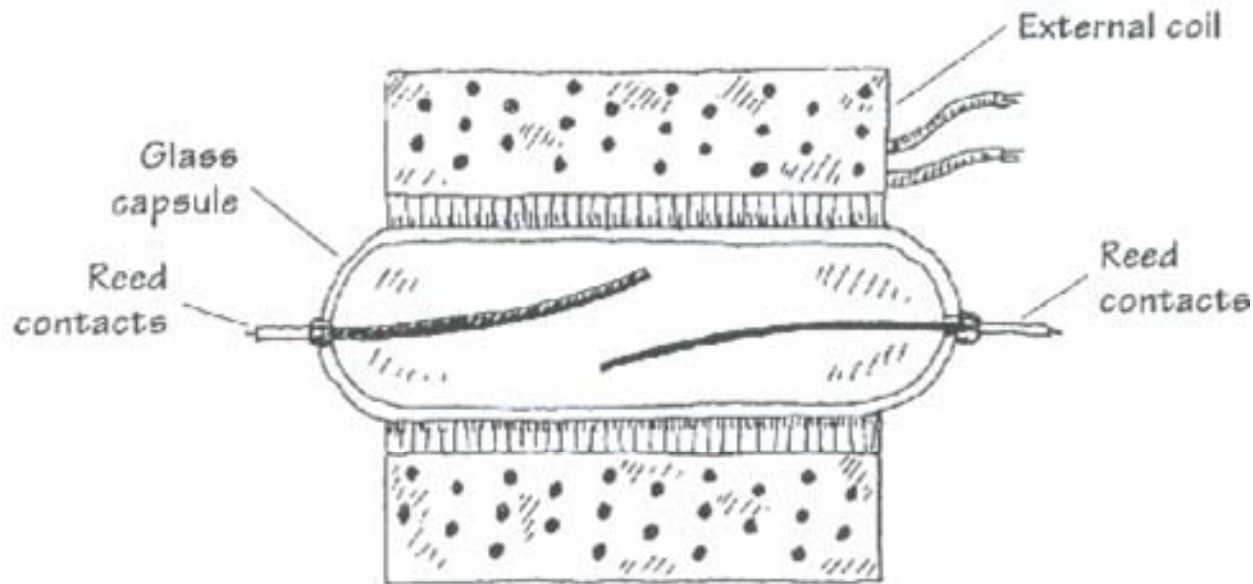

- Designed for moderate currents
 - Typically from 500mA to 1A
- Moderately fast switching
 - 0.2ms to 2ms

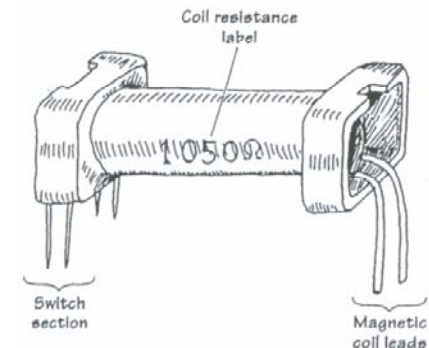

Description

- Contains two magnetizable and electrically conductive reeds
- Magnetic field will cause the contacts to pull together

Solid State Relays

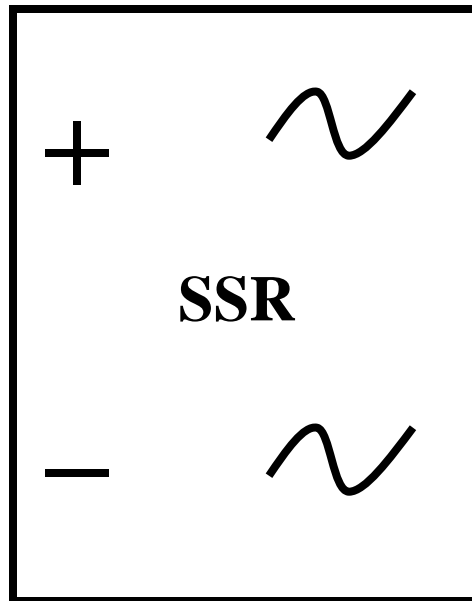

- Contains no moving parts
- Wide range of current ratings
 - from a few μA to 100A
- Extremely fast switching
 - 1 to 100 ns

Solid State Relay with AC

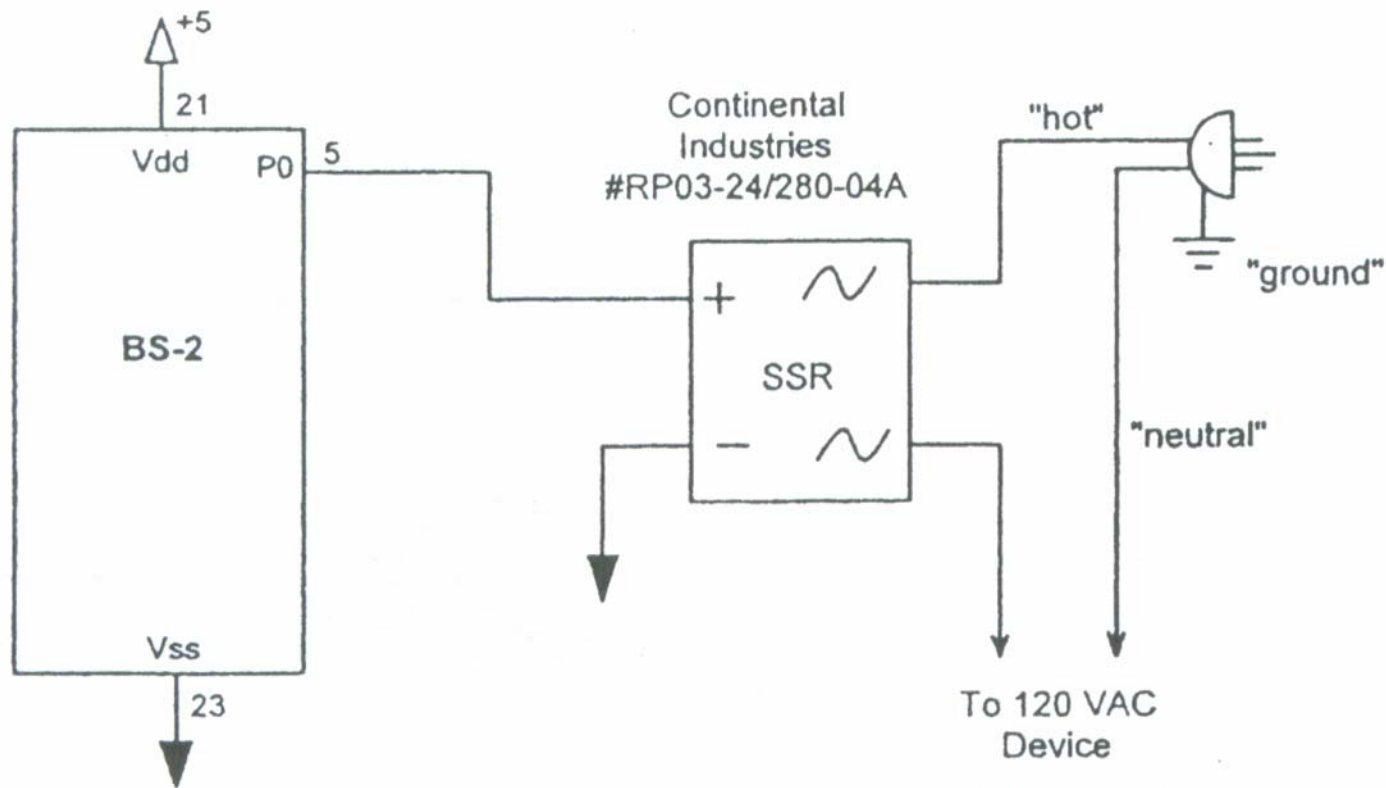

Extremely caution with 120V AC !!

Relay Experiments

Experiments	Chapters
What's micro controller	
Basic A and D	
Process Control	
Boe Bot Robotics	
Smart Sensors	
Others	

Lecture 15

DC Motor

DC Motor



- DC motors are
 - Simple two-lead
 - Electrically controlled
- The voltage range of the DC motor is
 - 1.5V ~ 48V

DC Motor: How It Works

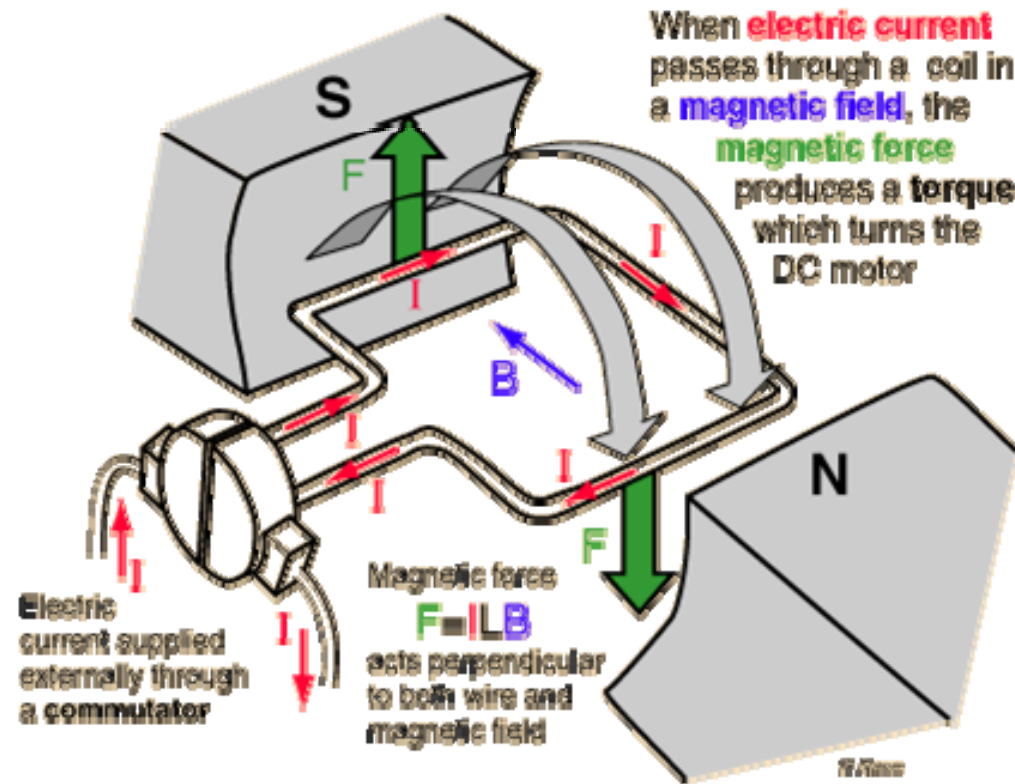

Turning a DC Motor On/Off

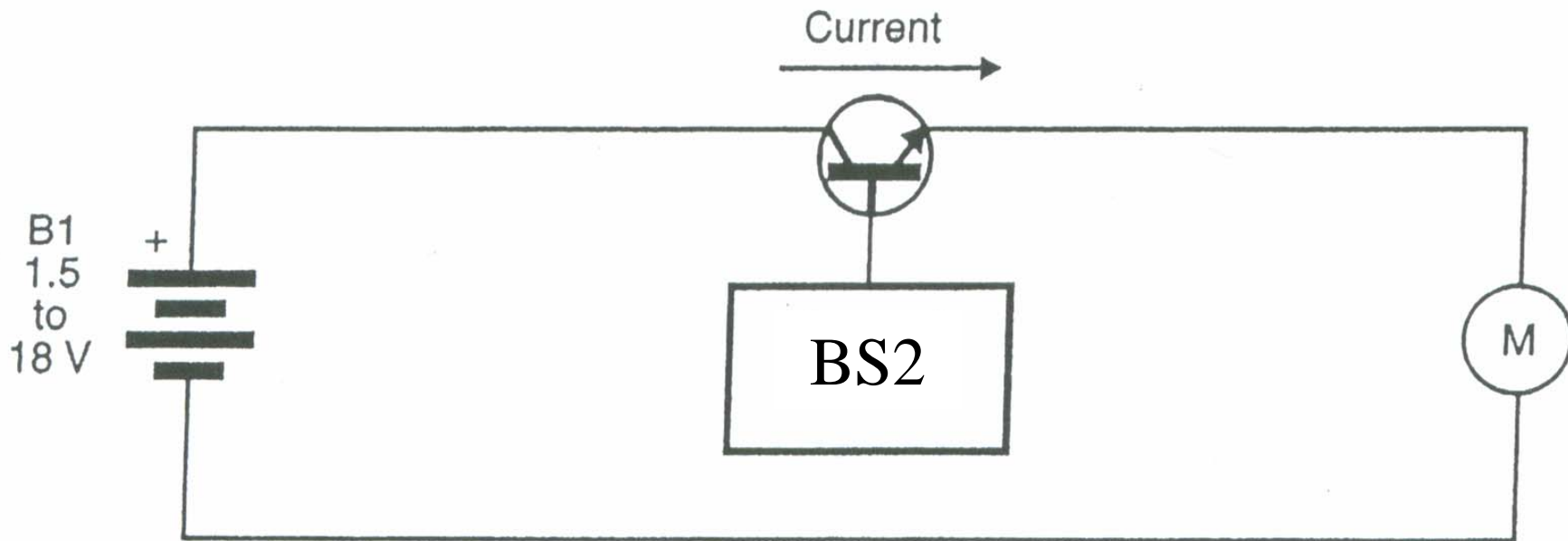

DC Motor Speed Control 1

- When the voltage applied to a DC motor
 - Lower than nominal voltage → Motor runs slower
 - Higher than nominal voltage → Motor runs faster
- Linear control
 - Connect a potentiometer in series with motor
 - Use a transistor (BJT/FET) as a variable resistor

DC Motor Speed Control 2

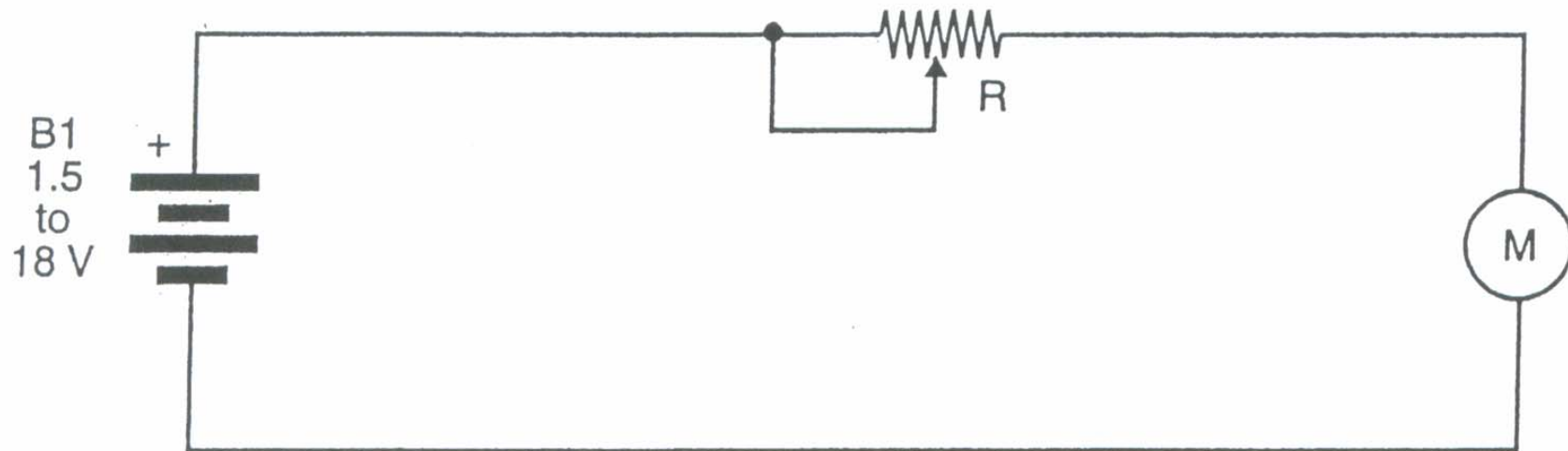

Linear control using a potentiometer in series with motor

DC Motor Speed Control 3

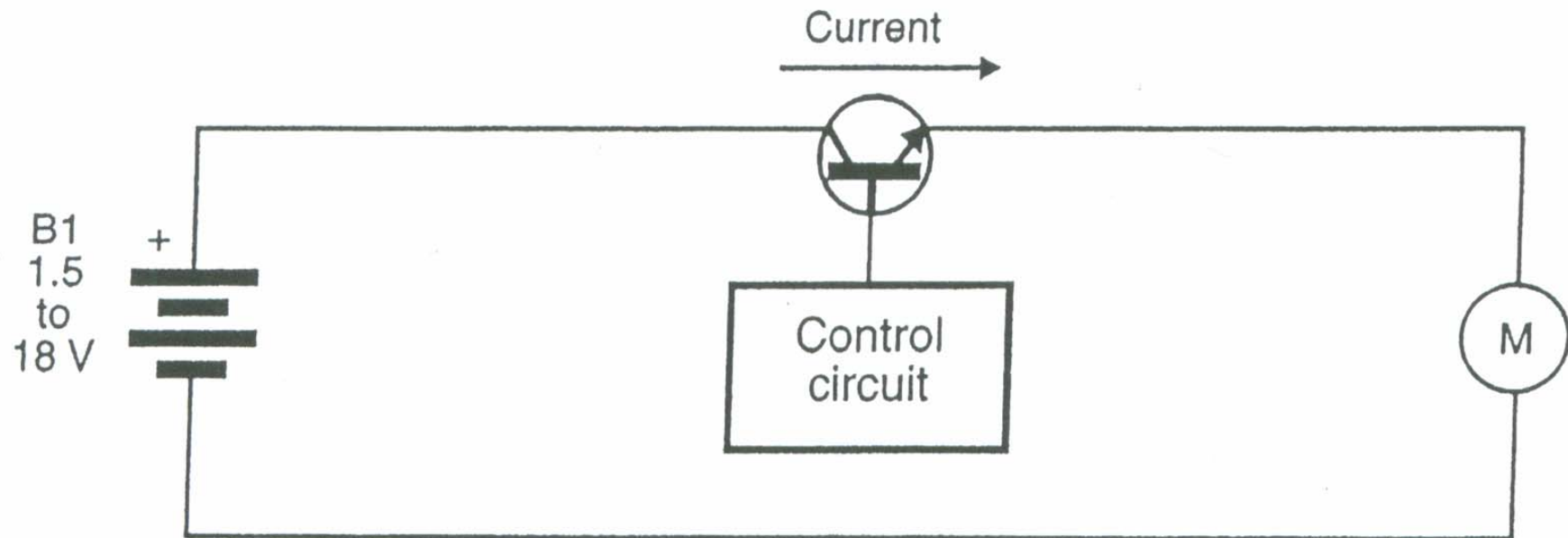

Linear control using a bipolar transistor

Pulse Width Modulation 1

- An efficient method to deliver controlled amount of power to loads
- Use square voltage pulses to power a load
- The amount of power deliver to load depends on the duration of each pulse

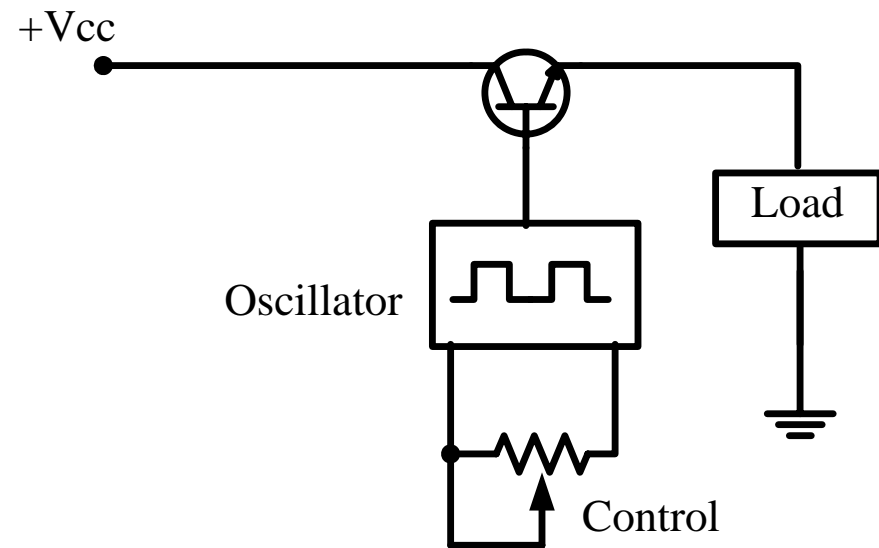

Basic PWM control

Pulse Width Modulation 2

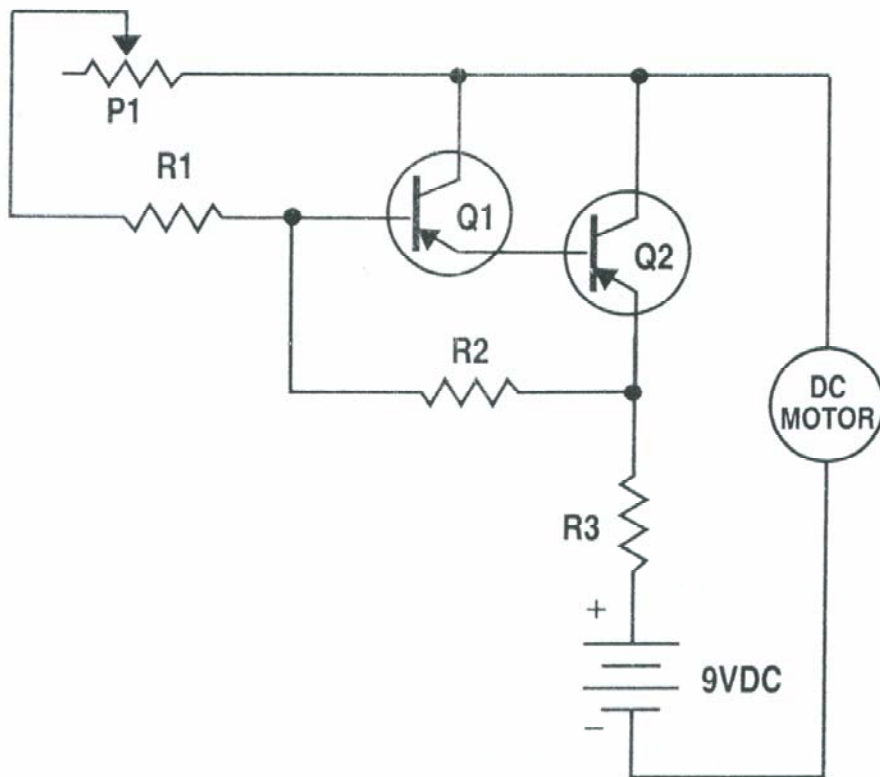

P1	50k Potentiometer
M1	DC Motor
Q1	PNP Transistor
Q2	PNP Transistor
R1	1k Ω
R2	15k Ω
R3	12 Ω

Pulse-Width-Modulation 3

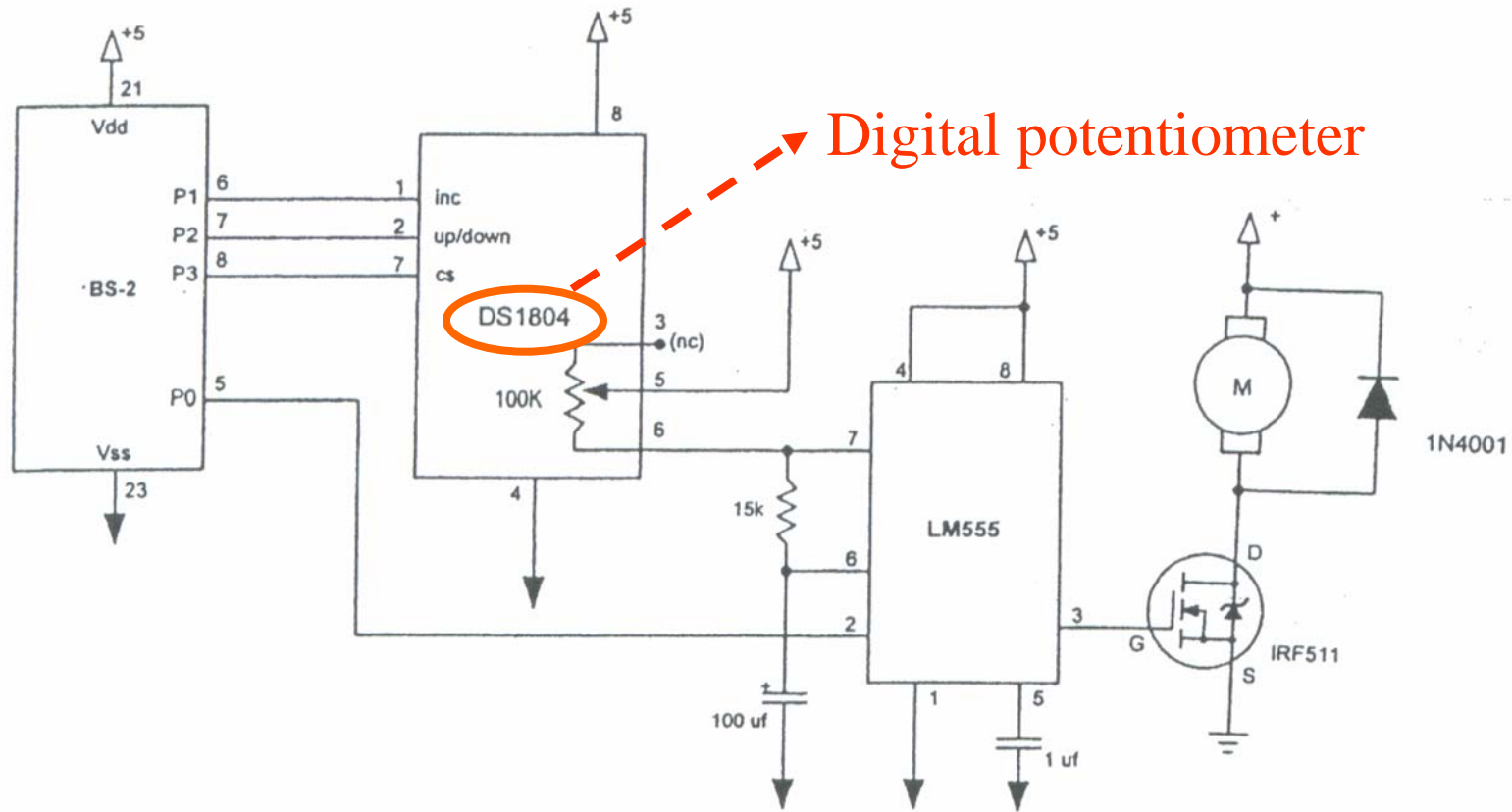

Controlling on-time duration of a DC motor

Pulse-Width-Modulation 4

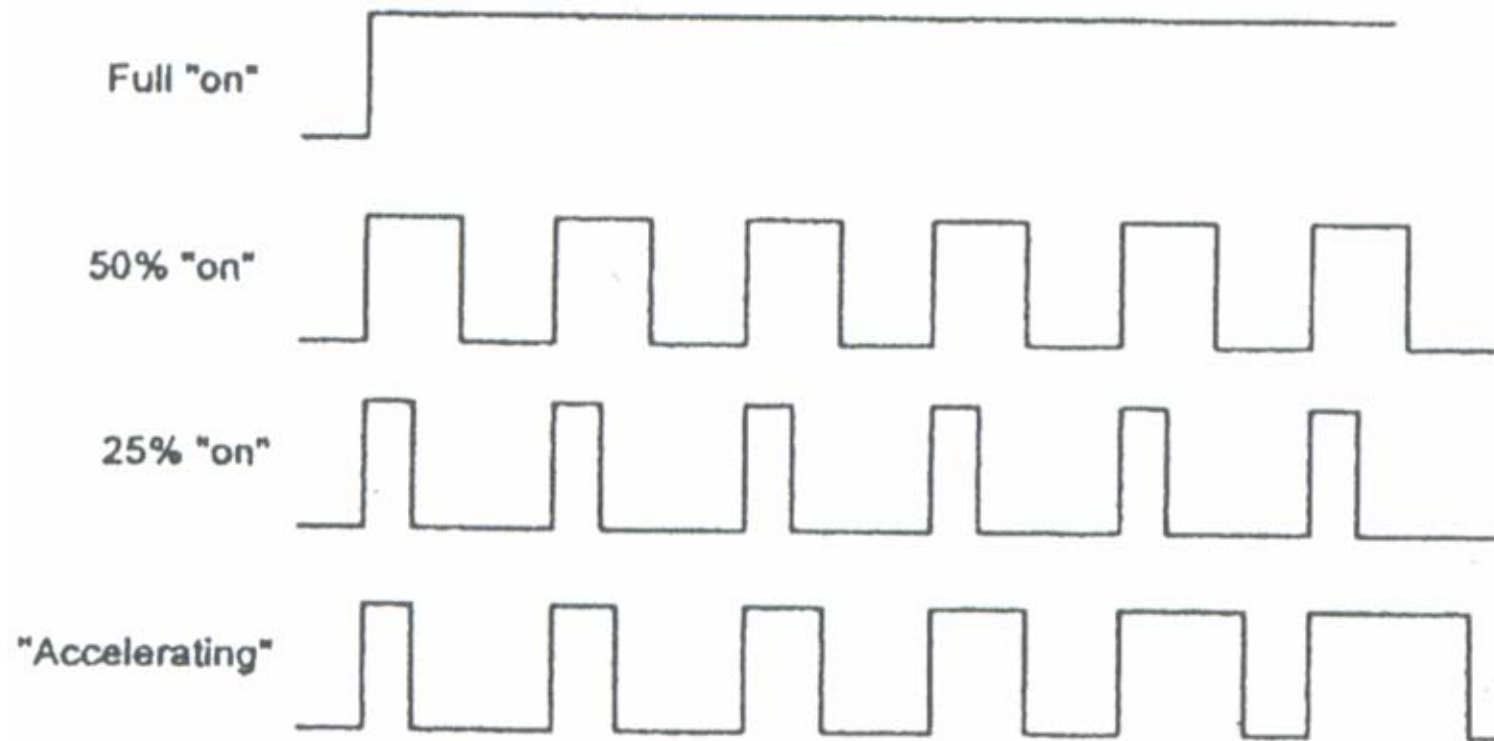

PWM