

Experiment 6: Level Control of a Coupled Water Tank

Concepts emphasized: Dynamic modeling, time-domain analysis, and proportional-plus-integral control.

1. Introduction

Industrial applications of liquid level control abound, e.g., in food processing, beverage, dairy, filtration, effluent treatment, and nuclear power generation plants; pharmaceutical industries; water purification systems; industrial chemical processing and spray coating; boilers; and automatic liquid dispensing and replenishment devices. The typical actuators used in liquid level control systems include pumps, motorized valves, on-off valves, etc. In addition, level sensors such as displacement float, capacitance probe, pressure sensor [1], etc. provide liquid level measurement for feedback control purpose. In this laboratory exercise, the students model, calibrate, and control a two-tank level control system. In particular, this experiment exposes the students to the fundamental modeling principle of fluid mass balance, pressure sensor calibration, and a feedback control design methodology for a state-coupled, two-tank level control system.

2. Background

System Modeling: The schematic drawing in Figure 1 represents the model of a two degree-of-freedom (DOF) state-coupled, water tank system. This system consists of two tanks with orifices and level sensors at the bottom of each tank, a pump, and a water basin. The two tanks have same diameters and can be fitted with different diameter outflow orifices. In this laboratory setup, the pump provides infeed to Tank 1 and the outflow of Tank 1 becomes infeed to Tank 2. The outflow of Tank 2 is emptied into the water basin. The following conditions with regard to the system dynamic model are used to describe the level of water in Tanks 1 and 2.

- i)* The water levels in Tanks 1 and 2 are measured by two pressure sensors;
- ii)* the level of water in Tank 1 is always less than 30 cm;
- iii)* the desired level of water in Tank 2 is always greater than 0 cm and less than 20 cm;
- iv)* the voltage applied at the input terminals of the pump is between 0 and 22 Volts.

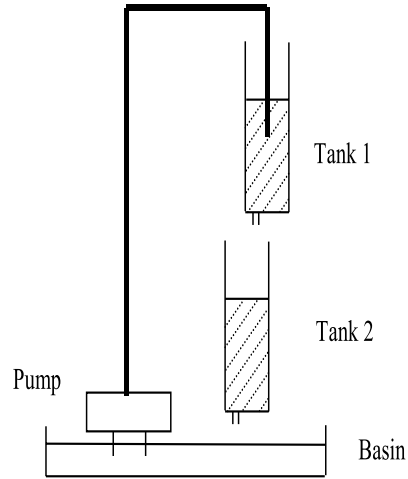

Figure 1: State-Coupled Two-Tank System

Based on the above assumptions, the dynamic equations for the liquid level in the two tanks are derived as follows. Note that for each tank the time rate of change of liquid level is given by

$$\dot{L}_i(t) = \frac{1}{A_i} (F_i^{\text{in}}(t) - F_i^{\text{out}}(t)) \quad \frac{\text{cm}}{\text{sec}}, \quad i = 1, 2, \quad (2.1)$$

where L_i , A_i , F_i^{in} , and F_i^{out} are the liquid level, cross-sectional area, inflow rate, and outflow rate, respectively, for the i^{th} tank. Next, note that the inflow rate to Tank 1 is given by

$$F_1^{\text{in}}(t) = K_p V_p \quad \frac{\text{cm}^3}{\text{sec}}, \quad (2.2)$$

where K_p is the pump constant ($\frac{\text{cm}^3}{\text{Volts-sec}}$) and V_p is the voltage applied to the pump. In addition, using Bernoulli's law for flow through small orifices, the outflow velocity from the orifice at the bottom of each tank is

$$v_i^{\text{out}}(t) = \sqrt{2gL_i} \quad \frac{\text{cm}}{\text{sec}}, \quad i = 1, 2. \quad (2.3)$$

Then, the outflow rate for each tank is given by

$$F_i^{\text{out}}(t) = a_i \sqrt{2gL_i} \quad \frac{\text{cm}^3}{\text{sec}}, \quad i = 1, 2, \quad (2.4)$$

where g is the gravitational acceleration and a_i denotes the cross-sectional area of the outflow orifice at the bottom of the i^{th} tank. Finally, note that for the two-tank level control system shown in Figure 1

$$F_2^{\text{in}}(t) = F_1^{\text{out}}(t). \quad (2.5)$$

Thus, using (2.1)–(2.5), we obtain the dynamic equations for the liquid level in the two tanks as

$$\dot{L}_1(t) = -\frac{a_1}{A_1}\sqrt{2gL_1(t)} + \frac{K_p}{A_1}V_p(t), \quad (2.6)$$

$$\dot{L}_2(t) = \frac{a_1}{A_2}\sqrt{2gL_1(t)} - \frac{a_2}{A_2}\sqrt{2gL_2(t)}. \quad (2.7)$$

Remark 2.1. Note that using (2.6), we can compute the steady-state pump voltage V_{pss} that produces the desired steady-state constant level $L_{1\text{ss}}$ in Tank 1. Specifically, setting $\dot{L}_1(t) = 0$ in (2.6) yields

$$V_{\text{pss}} = a_1 \frac{\sqrt{2gL_{1\text{ss}}}}{K_p}. \quad (2.8)$$

In a similar manner, we can compute the steady-state level $L_{1\text{ss}}$ in Tank 1 that produces the desired steady-state constant level $L_{2\text{ss}}$ in Tank 2. Specifically, setting $\dot{L}_2(t) = 0$ in (2.7) yields

$$L_{1\text{ss}} = \left(\frac{a_2}{a_1}\right)^2 L_{2\text{ss}}. \quad (2.9)$$

Now, theoretically one can use (2.8), (2.9) to regulate the water level in Tank 2. However, external disturbances, system parameter uncertainty/variation, etc., necessitate a feedback controller to improve the level control system performance.

Next, defining a set of shifted variables

$$\ell_1(t) \triangleq L_1(t) - L_{1\text{ss}}, \quad (2.10)$$

$$\ell_2(t) \triangleq L_2(t) - L_{2\text{ss}}, \quad (2.11)$$

$$u(t) = V_p(t) - V_{\text{pss}}, \quad (2.12)$$

we can rewrite the dynamic equations (2.6), (2.7) as

$$\dot{\ell}_1(t) = -\frac{a_1}{A_1}\sqrt{2g(\ell_1(t) + L_{1\text{ss}})} + \frac{K_p}{A_1}(u(t) + V_{\text{pss}}), \quad (2.13)$$

$$\dot{\ell}_2(t) = \frac{a_1}{A_2}\sqrt{2g(\ell_1(t) + L_{1\text{ss}})} - \frac{a_2}{A_2}\sqrt{2g(\ell_2(t) + L_{2\text{ss}})}. \quad (2.14)$$

Finally, linearizing (2.13), (2.14), about $(\ell_1 = 0, \ell_2 = 0, u = 0)$, we obtain

$$\dot{\ell}_1(t) = \alpha_1\ell_1(t) + \beta_1u(t), \quad (2.15)$$

$$\dot{\ell}_2(t) = \alpha_2\ell_2(t) + \beta_2\ell_1(t), \quad (2.16)$$

where

$$\begin{aligned}\alpha_1 &\triangleq -\frac{a_1}{A_1}\sqrt{\frac{g}{2L_{1ss}}}, & \beta_1 &\triangleq \frac{K_p}{A_1}, \\ \alpha_2 &\triangleq -\frac{a_2}{A_2}\sqrt{\frac{g}{2L_{2ss}}}, & \beta_2 &\triangleq \frac{a_1}{A_2}\sqrt{\frac{g}{2L_{1ss}}}.\end{aligned}\quad (2.17)$$

Next, we address the level control problem for Tank 2 (i.e., set-point tracking of $L_2(t)$) via a subsystem decomposition of (2.15), (2.16). In particular, we consider the level control for L_2 via the subsystem dynamics (2.16) with ℓ_2 and ℓ_1 as the subsystem output and input, respectively. The level control problem for the Tank 2 subsystem necessitates the control of level L_1 in Tank 1. The problem of controlling L_1 is addressed via the subsystem dynamics (2.15) with ℓ_1 and u as the subsystem output and input, respectively.

Now, we develop the transfer function models for the subsystem dynamics (2.15) and (2.16). Thus, taking the Laplace transform of (2.15) and arranging terms, we obtain

$$G_1(s) \triangleq \frac{\ell_1(s)}{u(s)} = \frac{\beta_1}{s - \alpha_1}, \quad (2.18)$$

where $\ell_1(s) \triangleq \mathcal{L}[\ell_1(t)]$ and $u(s) \triangleq \mathcal{L}[u(t)]$ and \mathcal{L} is the Laplace operator. Similarly, taking the Laplace transform of (2.16) and arranging terms, we obtain

$$G_2(s) \triangleq \frac{\ell_2(s)}{\ell_1(s)} = \frac{\beta_2}{s - \alpha_2}, \quad (2.19)$$

where $\ell_2(s) \triangleq \mathcal{L}[\ell_2(t)]$.

The numerical values of the parameters for the laboratory two-tank water level control system are provided in Table 1 below. Note that the variables α_i and β_i , for $i = 1, 2$, in (2.17) are computed with $L_{1ss} = L_{2ss} = 12$ cm.

Physical quantity	Symbol	Numerical value	Units
Tank 1, 2 diameters	D_1, D_2	4.425	cm
Tank 1, 2 orifice diameters	d_1, d_2	0.47625	cm
Pump constant	K_p	4.6	$\frac{\text{cm}^3}{\text{Volts-sec}}$
Gravitational constant	g	980	$\frac{\text{cm}}{\text{sec}^2}$

Table 1: Numerical Values for Physical Parameters of Two-Tank Level Control System

3. Objective

Proportional-plus-integral (PI) control of the state-coupled, two-tank system to track a desired level of water in Tank 2.

4. Equipment List

- i)* PC with MultiQ-3 data acquisition card and connecting board
- ii)* Software environment: Windows, Matlab, Simulink, RTW, and WinCon
- iii)* Water Tank apparatus with a water basin
- iv)* Universal power module: UPM-2405
- v)* Set of leads

5. Experimental Procedure

- i)* Using the set of leads, universal power module, water tank apparatus, and the connecting board of the MultiQ-3 data acquisition card, complete the wiring diagram shown in Figure 2.
- ii)* Start Matlab and WinCon Server. In the Matlab window, at the command prompt, type “Experiment6” and hit the **Enter** key. This Matlab script will change the directory from the default Matlab directory to the directory where all files needed to perform Experiment 6 are stored.
- iii)* You can now perform various steps for the level control of coupled water tanks. However, before proceeding, you **must** request your laboratory teaching assistant to check your electrical connections.
- iv)* From the **File** menu of the WinCon Server, select the option **Open** to load the experiment file “Experiment6_A.wcp.” This will load the files for calibrating the pressure sensor voltage when there is no water in Tanks 1 and 2. The voltage measured on S1 and S2 should be 0 Volts. A digital meter window will also appear on your desktop. Next, from the **Window**

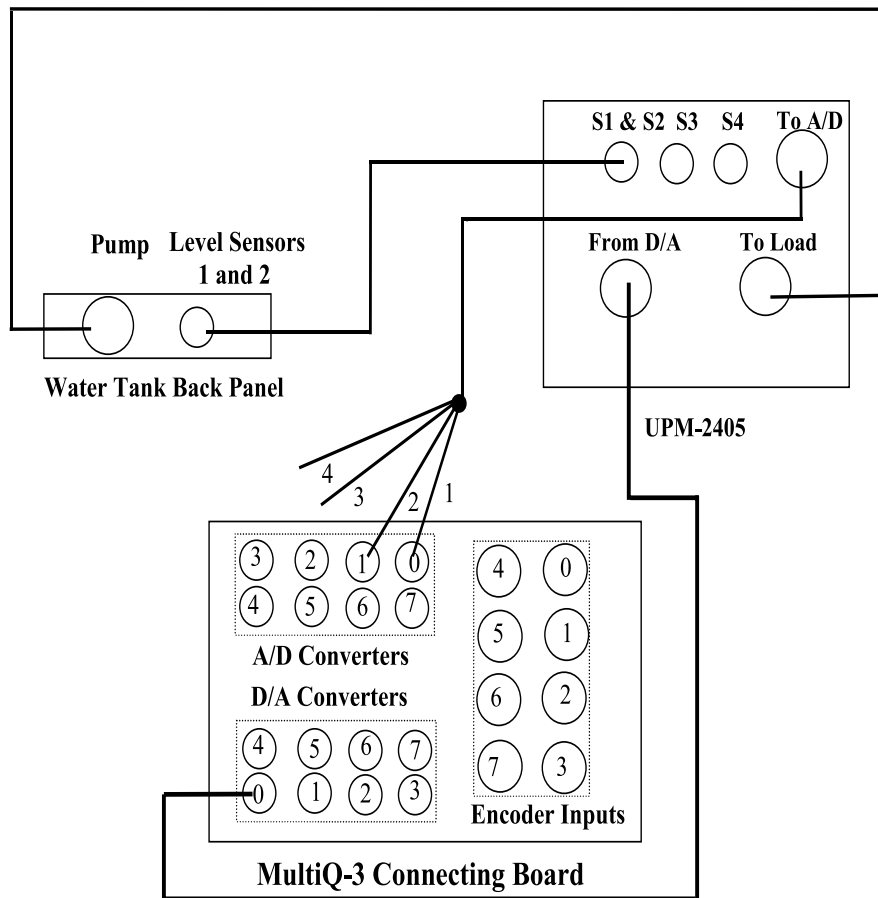

Figure 2: Wiring Diagram for Two-Tank Level Control

menu of the WinCon Server, select the option **Simulink**. This will load the Simulink block diagram “Experiment6_A.mdl” shown in Figure 3 to your desktop.

- a) In the WinCon Server interface, click the green **Start** button to acquire the voltages measured on S1 (the level of water in Tank 1) and S2 (the level of water in Tank 2).
- b) Adjust the offset **potentiometers** 1 and 2 on the water tank apparatus back panel to obtain 0 Volts.
- c) In the WinCon Server interface, click the red **Stop** button when you finish calibrating the sensor off-set.

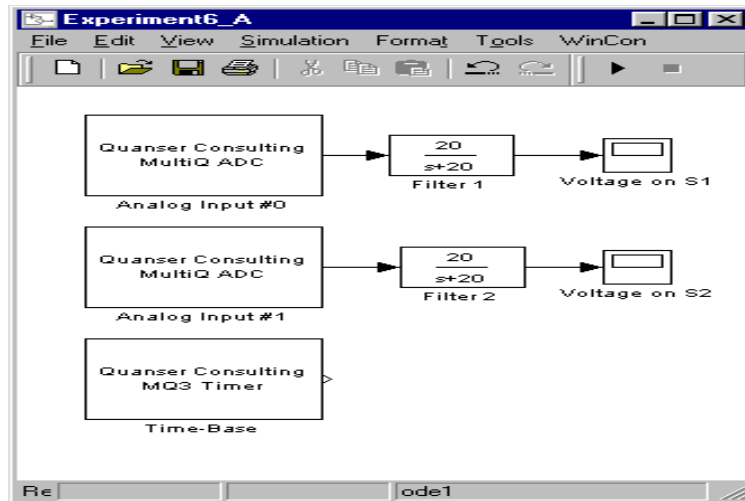

Figure 3: Simulink Block-Diagram for Water Pressure Sensor Offset and Gain Calibration

- v) Fill water into Tank 1 upto the 25 cm level. The voltage measured on S1 should now be about **4.1** Volts.
 - a) In the WinCon Server interface, click the green **Start** button to acquire the voltage measured on S1 (pressure sensor).
 - b) Adjust the gain **potentiometer** 1 on the water tank apparatus back panel to obtain any where between **4.0 to 4.2** Volts on S1 (pressure sensor).
 - c) In the WinCon Server interface, click the red **Stop** button when you finish calibrating the sensor gain.
- vi) Repeat (v) for Tank 2.
- vii) Close the currently opened plot windows and the Simulink diagram. From the **File** menu of the WinCon Server, select the option **Open** to load the experiment file “Experiment6_B.wcp.” A plot window will also appear on your desktop. Next, from the **Window** menu of the WinCon Server, select the option **Simulink** which loads the Simulink file “Experiment6_B.mdl” shown in Figure 4 to your desktop. The various Simulink subblocks used in Figure 4 are given in detail in Figures 5 and 6.
 - a) At the Matlab command prompt, execute the script **Experiment6**. This will assign the numerical values of the physical parameters of the two-tank level control

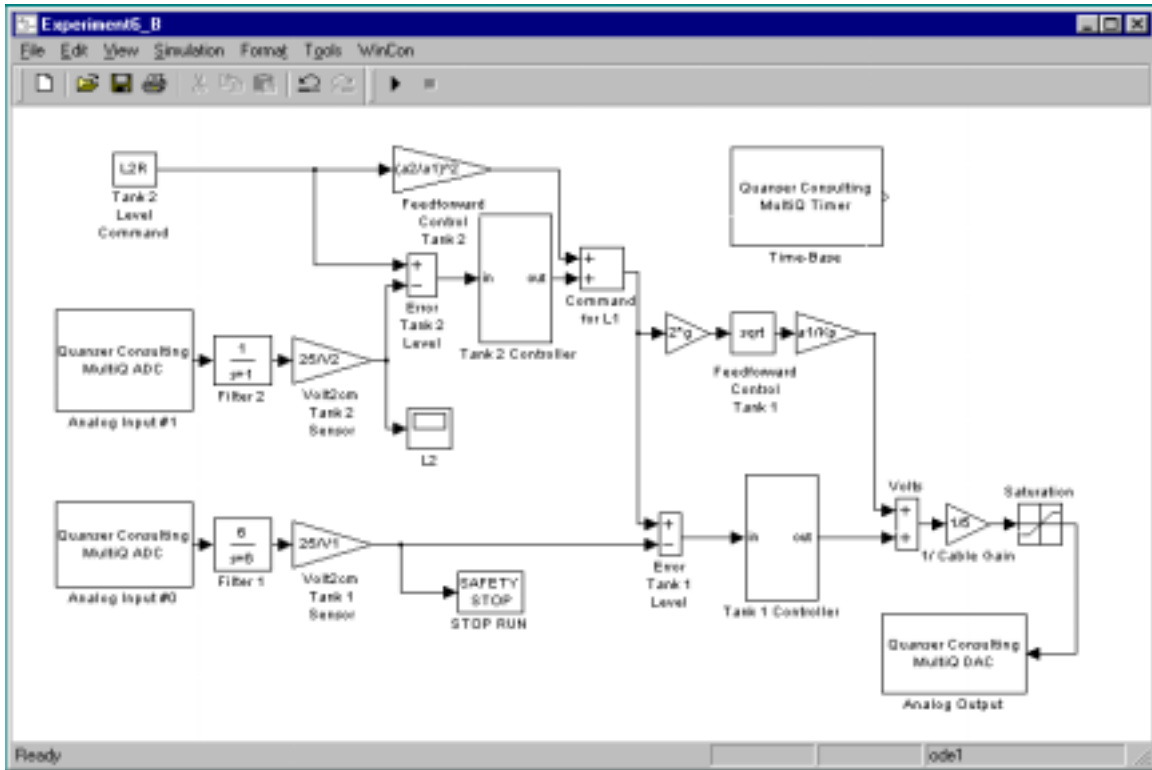

Figure 4: Simulink Block-Diagram for Two-Tank System PI Control

system.

- b) In Figure 4, under the subblock labeled **Tank 1 Controller** (Figure 5), the gains k_{p1} and k_{i1} must be designed and supplied by you. In particular, design a PI controller so that the closed-loop Tank 1 subsystem response exhibits a peak overshoot less than 1.5% and settling time less than 10 seconds. Note that $G_1(s)$ given by (2.18) denotes the open-loop transfer function for the Tank 1 subsystem. Furthermore, note that in Figure 4, a feedforward controller based on (2.12) is also implemented for the Tank 1 subsystem to account for the V_{pss} term in (2.12).
- c) In Figure 4, under the subblock labeled **Tank 2 Controller** (Figure 6), the gains k_{p2} and k_{i2} must also be designed and supplied by you. In particular, design a PI controller so that the closed-loop Tank 2 subsystem response exhibits a peak overshoot less than 3.5% and settling time less than 20 seconds. Note that $G_2(s)$ given by (2.19) denotes the open-loop transfer function for the Tank 2 subsystem. Furthermore, note that in Figure 4, a feedforward controller based on (2.10) is

implemented for the Tank 2 subsystem to account for the L_{1ss} term in (2.10).

- d) Before proceeding, you **must** request your laboratory teaching assistant to approve your gain values. In the WinCon Server interface, click the green **Start** button to acquire the transient and steady-state step response of the level of water in Tank 2.

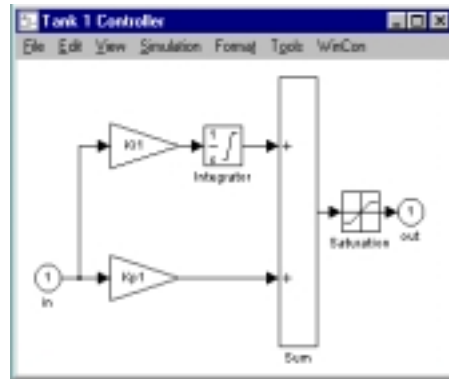

Figure 5: Tank 1 Controller Subblock

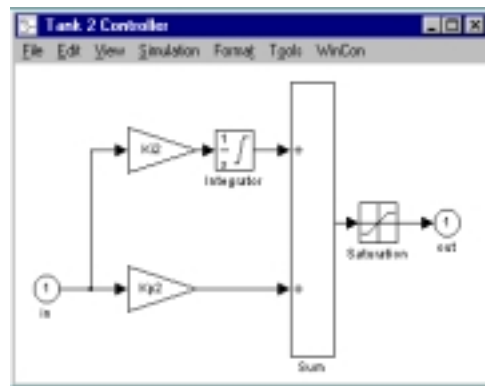

Figure 6: Tank 2 Controller Subblock

6. Analysis

- i)* Analyze the script “Experiment6.m” and the simulink control diagram “Experiment6_B.mdl.”
- ii)* Build a nonlinear simulation model (using Simulink) for the two-tank level control system. Note that as in the laboratory setup, for the simulation model the input voltage to the pump must be limited to 22 Volts. Obtain the open-loop response of the system. In addition, obtain the closed-loop response of the simulation model. How does the simulated system response compare with the experimental response?
- iii)* Obtain the closed-loop response for the simulation model of the two-tank level control system with *a)* only the PI controller and *b)* only the feedforward controller.
- iv)* Analyze and comment on your experimental results. Specifically, analyze the experimental time response of water levels in Tanks 1 and 2. Does the system response meet the performance specifications? Explain.
- v)* Obtain the experimental response of the two-tank system to disturbances. Note that addition of water into Tank 1 and/or Tank 2 from any source other than the pump constitutes an exogenous disturbance.

References

1. R. N. Bateson, *Introduction to Control System Technology*, Prentice-Hall, Upper Saddle River, NJ, 1999, 6th Ed., pp. 304–307.